

**Weather Hood Models - WH-1, WH-2, WH-3, WH-4**

**Design Features** – Protect louvers, dampers or fan systems from outside elements. Supplied with standard 1-1/2" flange on all sides ready for wall mount installation.

**STANDARD CONSTRUCTION**

**MATERIAL**

18 gauge galvanized steel – Galvanized construction  
 .063" thk. formed aluminum 5005-H34 – Aluminum construction

**ASSEMBLY**

Stitch welded construction

**MINIMUM SIZE**

Unlimited, with mullions, structural bracing supplied by others

**MAXIMUM FACTORY ASSEMBLY SIZE**

120" w x 60 h" x 60" d (allows for best handling)  
 (Type of finish may limit maximum single section)

**MINIMUM SIZE**

12" x 12" x 12"

**UNDERSIZED**

1/4" under ordered size unless specified Exact or Actual

**SCREEN**

1/2" Mesh x 19 ga. galvanized screen – Galvanized construction  
 3/4" Mesh x 050 expanded alum. screen – Aluminum construction

**FINISH**

Mill

**OPTIONAL CONSTRUCTION**

**MATERIAL** – Available in heavier construction

**SCREEN** - Many styles available please consult screen listing

**FINISH** – Air-dry primer, polyurethane, epoxy, or enamel, baked epoxy or enamel, Kynar, or Powder coat.

**SPECIAL PURPOSE CONSTRUCTION**

Fully welded construction

Security bars

Filter racks

Hinged as walk through door or for swing out for access

Sleeved for ductwork connection

\*\* Consult DOWCO for additional technical information.

**TYPICAL SCREEN STYLES**

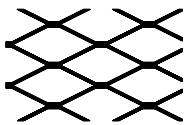

Expanded Aluminum  
Std. for alum. const.

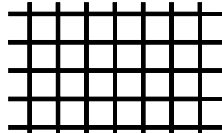

Wire Mesh  
Std. for galv. const.

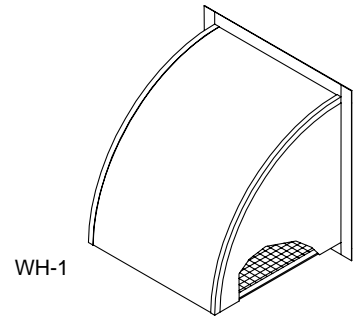

WH-1

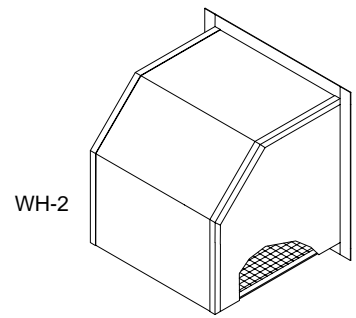

WH-2

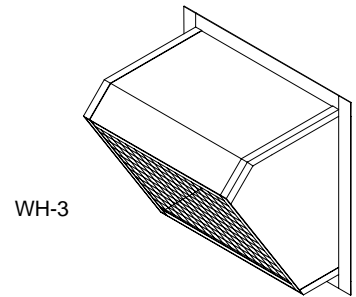

WH-3

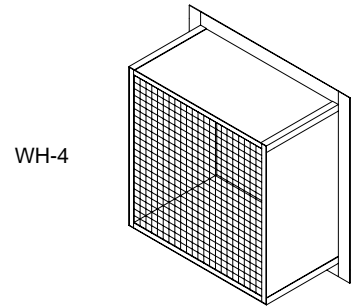

WH-4

DATE	ARCHITECT			CUSTOMER
PROJECT				
ITEM	QTY	W	H	DESCRIPTION



DEPENDABLE PRODUCTS SINCE 1955

**SAFE-AIR/DOWCO**

*Engineering and General Offices*

1855 South 54<sup>th</sup> Avenue, Cicero, Illinois 60804

Phone 708-652-9100 FAX 708-652-9158